

■ 特長 FEATURES

- 樹脂遊星ギヤタイプ
- 樹脂による静粛性・高トルク重視
- Plastic planetary gear type
- Emphasis on high torque and quietness by plastic

RoHS 指令対応 RoHS compliant



■ 型式表示 PART NUMBER DESIGNATION

HG37 - 060 - AB - 00

Series name

Rated voltage

A : 12 VDC B : 24 VDC

Gear ratio

010 : 1/10 030 : 1/30 060 : 1/60 120 : 1/120
150 : 1/150 200 : 1/200 300 : 1/300

■ 型式および仕様一覧表 LIST OF PART NUMBERS & SPECIFICATIONS

型式名 Model	定格電圧 Rated voltage [V]	減速比 Gear ratio		定格(推奨)負荷 Rated (recommended) load			無負荷 No-load		起動 Stall		許容トルク Allowable torque [mNm]	最大出力 Maximum output power [W]	質量 Mass [g]
		呼称 Nominal	[1/x]	トルク Torque [mNm]	回転数 Speed [min ⁻¹]	電流 Current [mA]	回転数 Speed [min ⁻¹]	電流 Current [mA]	トルク Torque [mNm]	電流 Current [mA]			
HG37-010-AB-00	24	10	8.75	29	460	150	570	40	150	600	44	2.3	140
HG37-030-AB-00		30	28.88	98	140	150	173	40	520	600	147	2.4	
HG37-060-AB-00		60	57.75	196	70	150	87	40	980	600	294	2.3	
HG37-120-AB-00		120	123.25	392	33	140	41	40	2100	600	588	2.4	155
HG37-150-AB-00		150	153.26	490	27	150	33	40	2600	600	588	2.4	
HG37-200-AB-00		200	190.58	588	22	140	26	40	3300	600	588	2.3	
HG37-300-AB-00		300	306.52	588	14.5	100	16.3	40	5400	600	588	2.3	

■ 外形寸法図 OUTLINE DIMENSIONS

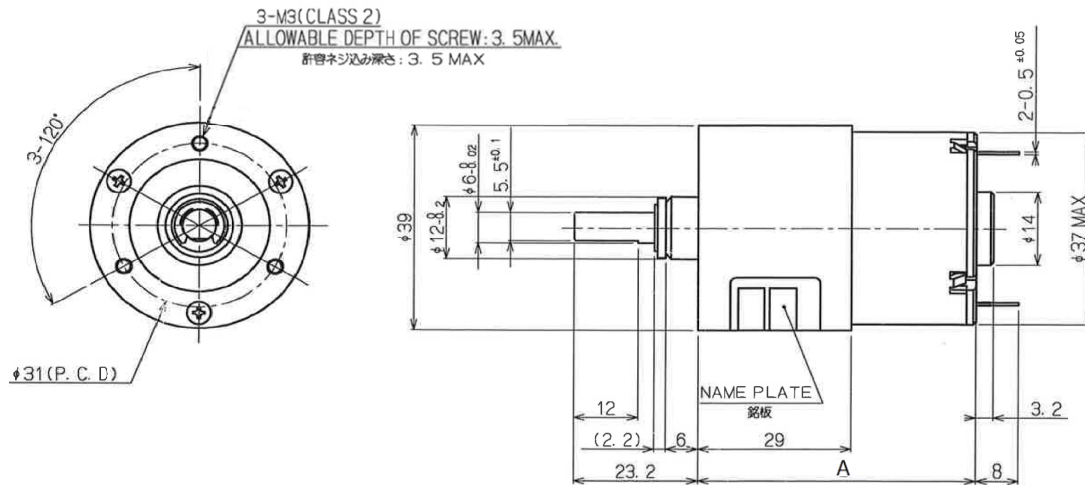

Mark A [mm]

Gear ratio	1/10	1/30	1/60	1/120	1/150	1/200	1/300
A	38.5	46.5	52				

■ PERFORMANCE CURVES

(Figures in the table are typical values under rated operating condition.)

