

Horizontal Machining Center

HM1600

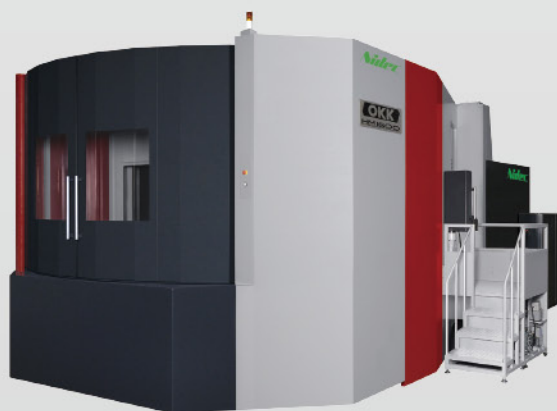

Large Capacity, High-Speed Horizontal Machining Center

HM1600

Combining exceptional cutting capability with high-speed and accuracy to optimize the machining of wind-power amplifier gear boxes, large-size dies and molds, diesel engine blocks and other large products.

Travel Distance

2400(94.49") X **1650**(64.96") X **1750**(68.90") mm

Pallet Size

1600 (62.99") X **1250**(49.21") mm

Maximum Workpiece Size (Diameter x Height)

∅2500 (98.43") X **1850**(72.83") mm

Rapid Traverse Rate (X/Y/Z axes)

42m/min(1654ipm)

Maximum Tool Mass

30kg(66.1lbs)

Maximum Tool Diameter

∅300mm(11.81")

Maximum Tool Length

600mm(23.62")

Number of Stored Tools

60 tools

*116, 176 or 236 tools can be stored optionally.

Maximum Load Mass

5000kg(11013lbs)

*8000 kg (17621lbs) or 10000 kg (22026lbs) can be loaded optionally.

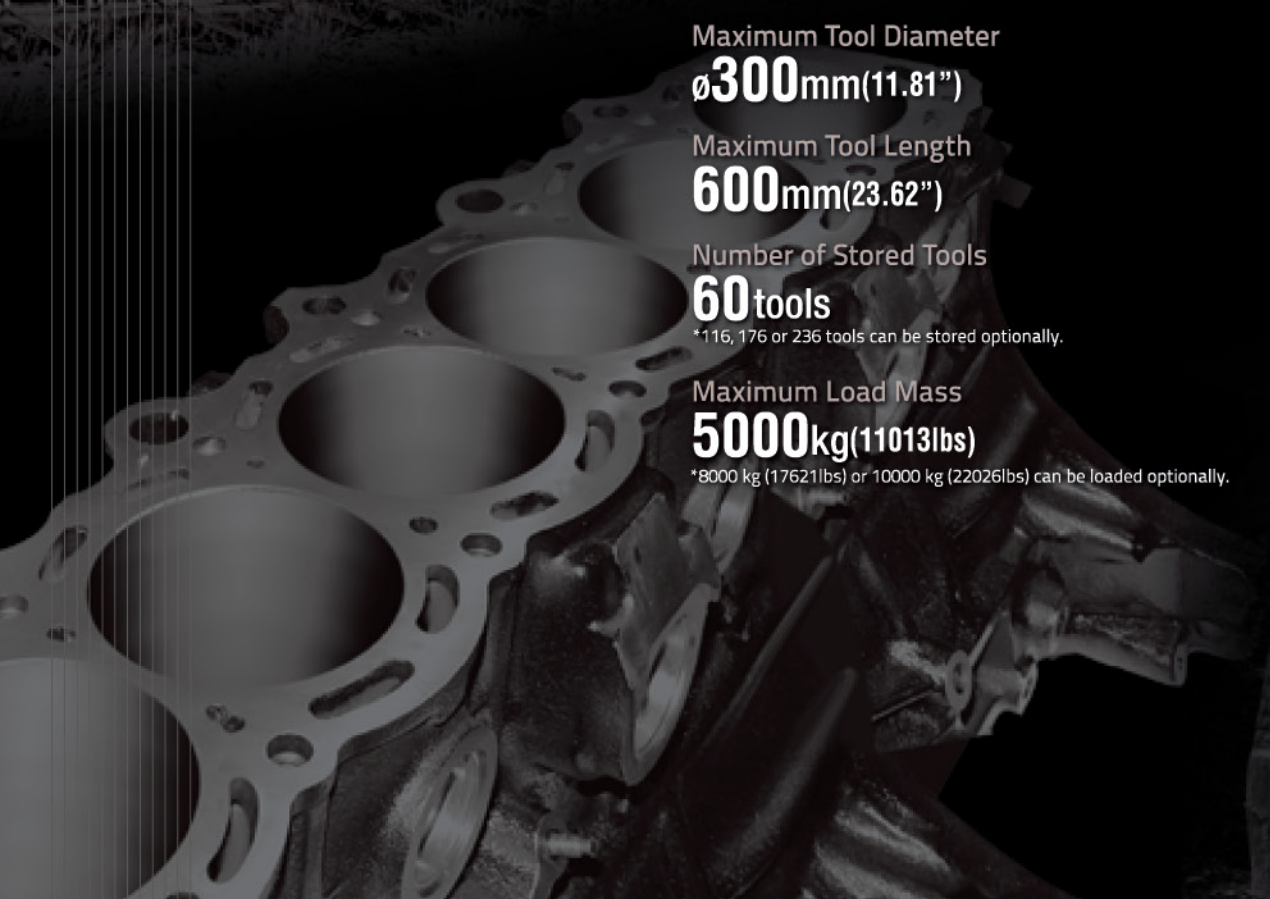
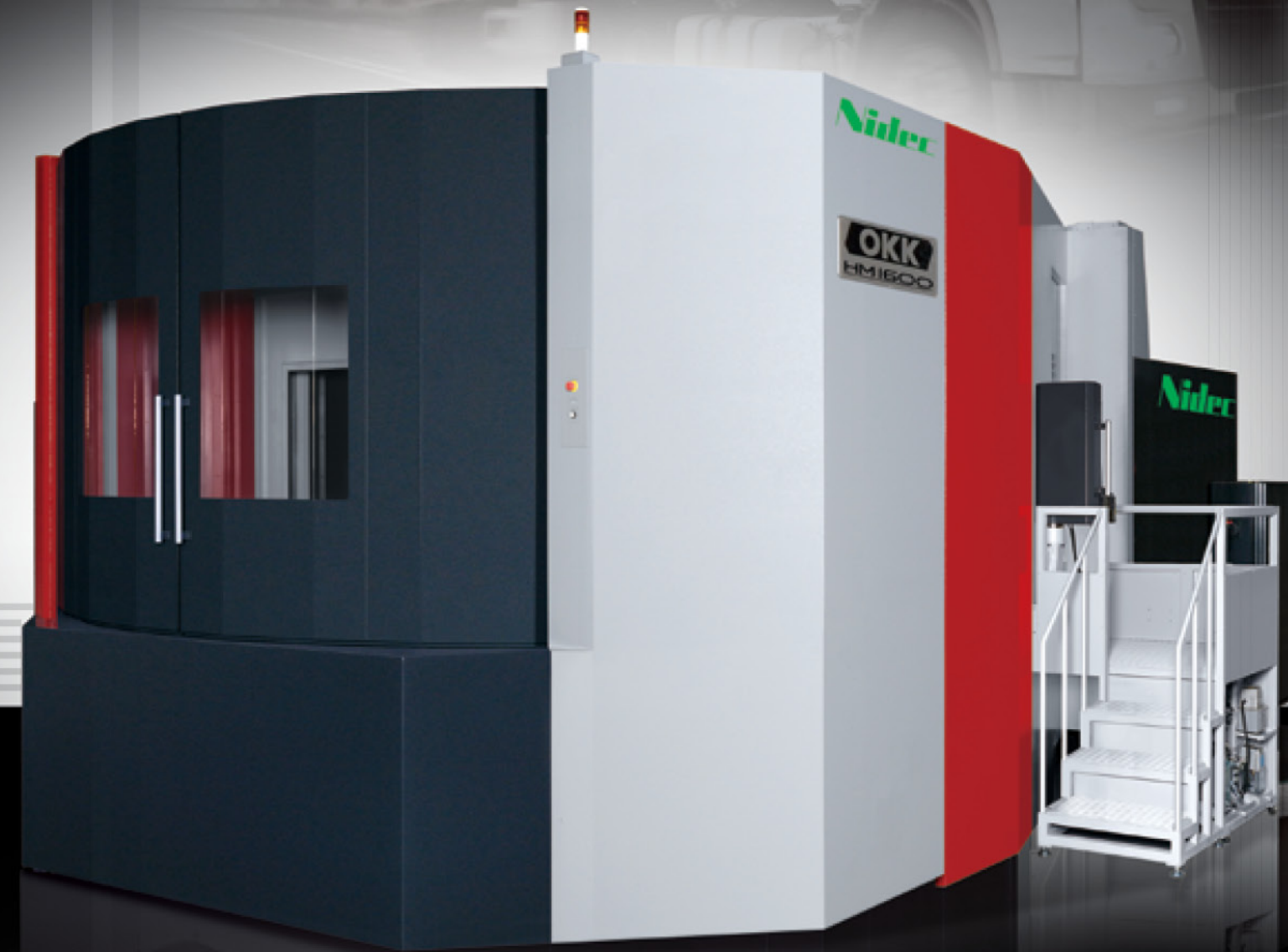

Consistent machining performance is received by the precise synchronization of the control and the drives.

Synchronized control of the Y and Z axes drives and the large-diameter twin-lead ball screws

Provision of spindles to respond to any users' demands

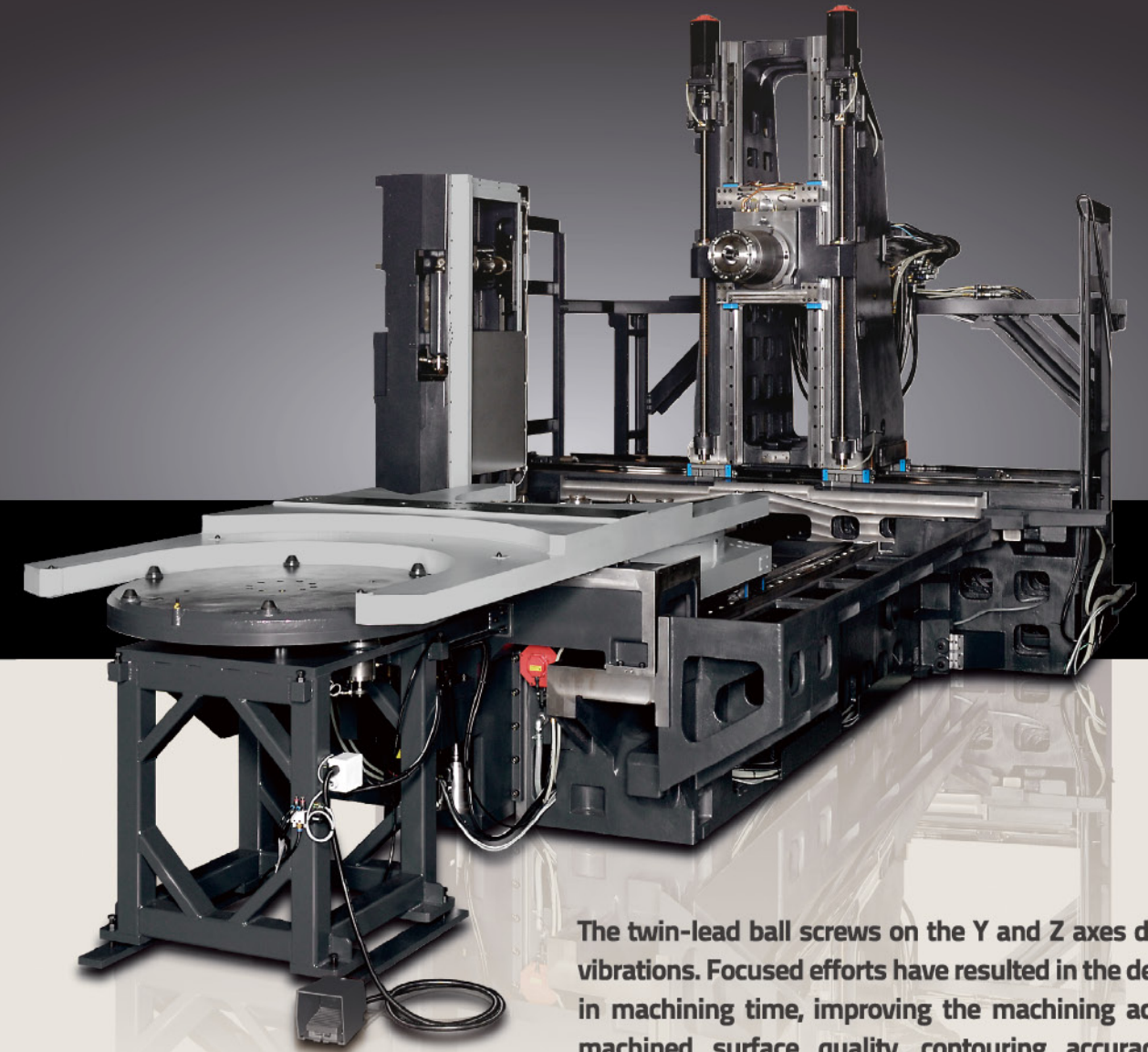

The twin-lead ball screws on the Y and Z axes dampen vibrations. Focused efforts have resulted in the decrease in machining time, improving the machining accuracy, machined surface quality, contouring accuracy and extending the tool life.

High-speed Spindle (MS)

For high-speed and high efficient machining of general parts

Spindle rotating speed: 35 through 12000 min⁻¹
Spindle motor: 30 kW (40HP) (30-min rating) / 25 kW (34HP)(continuous rating)
Maximum spindle torque: 420 N·m (310ft·lbs)(25% ED rating) / 238 N·m (176ft·lbs)(continuous rating)
Spindle bearing bore diameter: ø100 mm (3.94")

Optional Output-increased Spindle Motor

Spindle motor:
45kW (60HP)(25% ED rating) / 26kW (35HP)(continuous rating)
Maximum spindle torque:
623 N·m (460ft·lbs)(15% ED rating) / 305 N·m (225ft·lbs)(continuous rating)

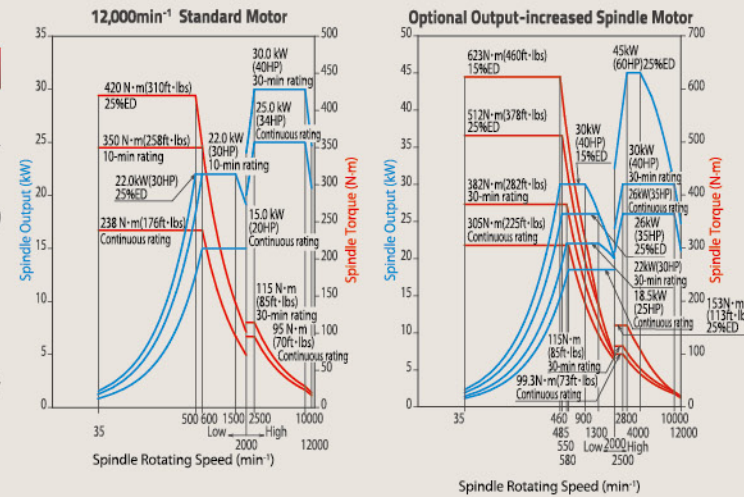
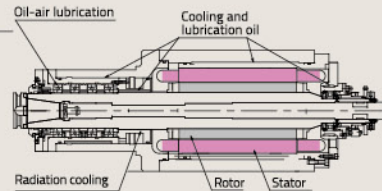

Gear-drive Spindle (Three-step Gear Drive)

For smoothly machining the hard-to-cut materials for heavy-duty parts

8000min⁻¹
Spindle rotating speed: 20 through 8000 min⁻¹
Spindle motor: 18.5kW (25HP)(30-min rating) / 15kW(20HP)(continuous rating)
Maximum spindle torque: 1052 N·m (776ft·lbs)(30-min rating) / 853 N·m (629ft·lbs)(continuous rating)
Spindle bearing bore diameter: ø120mm (4.72")

8000min⁻¹ Optional Output-increased Spindle Motor

Spindle rotating speed: 20 through 8000 min⁻¹
Spindle motor: 22kW(30HP)(30-min rating) / 18.5kW(25HP)(continuous rating)
Maximum spindle torque: 1250N·m(922ft·lbs)(30-min rating) / 1052N·m(776ft·lbs)(continuous rating)
Spindle bearing bore diameter: ø120mm (4.72")

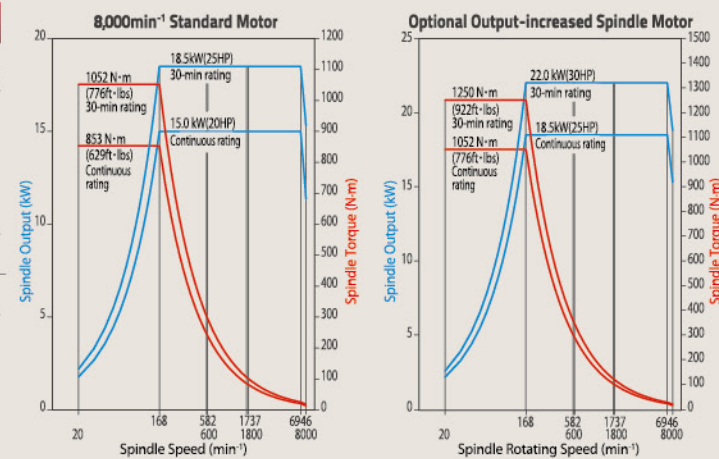
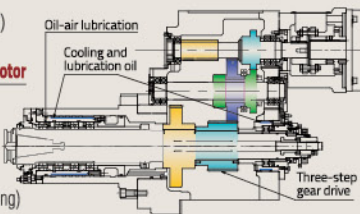

Gear-drive Spindle (Three-step Gear Drive)

For smoothly machining the hard-to-cut materials for heavy-duty parts

6000min⁻¹
Spindle rotating speed: 20 through 6000 min⁻¹
Spindle motor: 45kW (60HP)(30-min rating) / 37kW(50HP)(continuous rating)
Maximum spindle torque: 2193 N·m (1617ft·lbs)(30-min rating) / 1803 N·m (1330ft·lbs)(continuous rating)
Spindle bearing bore diameter: ø120mm (4.72")

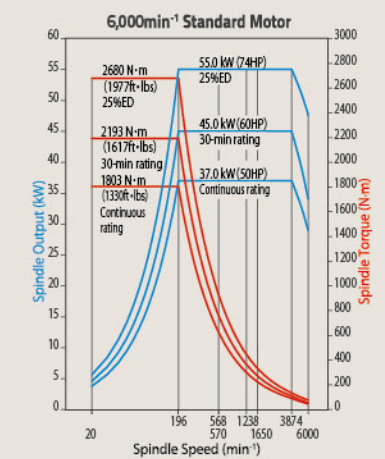
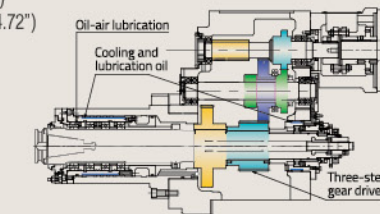

High-accuracy Positioning and High Clamping Force

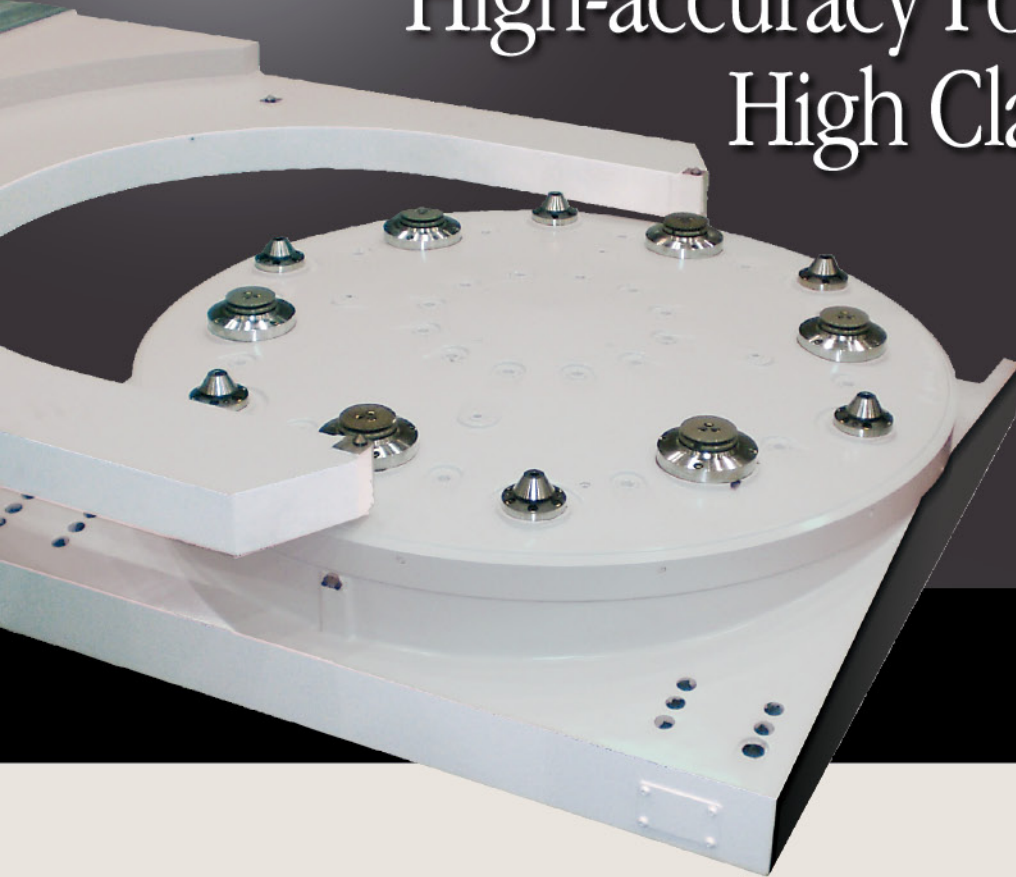

Nidec OKK's original six cylinder pallet clamping holds with a force of 284 kN and six taper cones produce high-accuracy positioning. The balanced clamping method and high clamping force delivers high cutting capability that is necessary for machining the large and heavy workpieces.

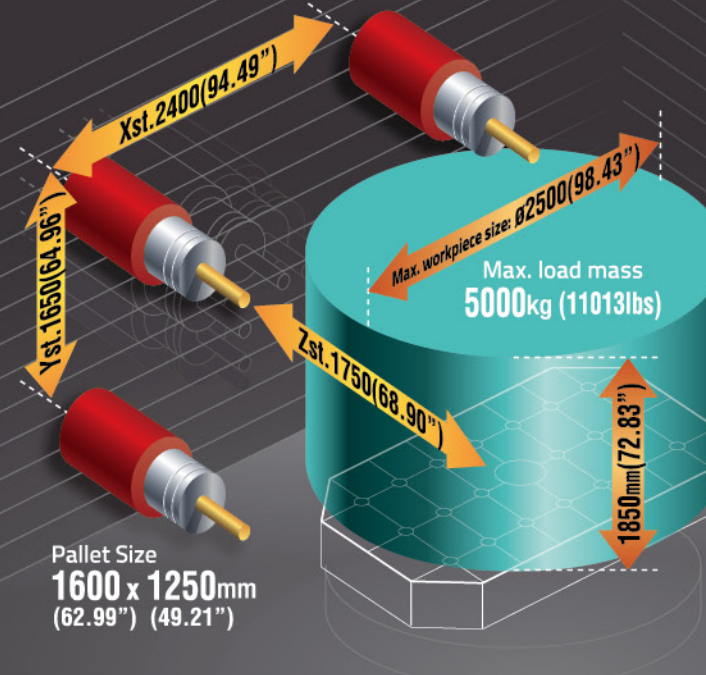

Hybrid guide supporting heavy workpiece Utilizing a large-diameter tapered roller bearing and the sliding guide surface on the B axis has produced a highly rigid table.

The built-in rotary table (BRT) is ideal for machining complicated workpieces and is included in the standard specification. It enables the 0.0001-degree minimum index angle.

Pallet Size
1600 x 1250mm
(62.99'') (49.21'')

Maximum Workpiece Size (Diameter x Height)
Ø2500 x 1850mm
(98.43'') (72.83'')

Maximum Load Mass
5000kg (11013lbs)

*8000 kg (17621lbs) or 10000 kg (22026lbs) can be loaded optionally. Note that the APC cannot be used for the 10000-kg (22026lbs) specification.

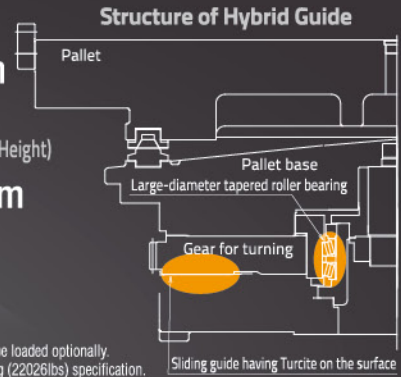

Wide Machining Area available for Large Workpieces

OKK pursued the ultimate superior accuracy, accessibility and operability by a thorough study of the heavy-duty cutting environment.

Forced Core Cooled Ball Screw and Double-anchoring Method

Lubrication Oil Temperature Controller



The forced core cooled ball screws are used on the X, Y and Z axes. Circulation of the temperature-controlled cooling oil on the surfaces of the ball screws, ball screw supports and motor mounting section minimizes the thermal displacement and provides continued accuracy over a long period of time.

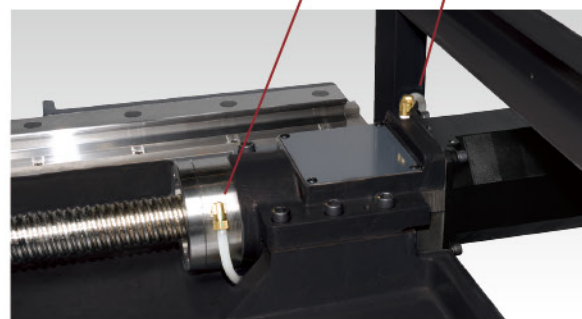
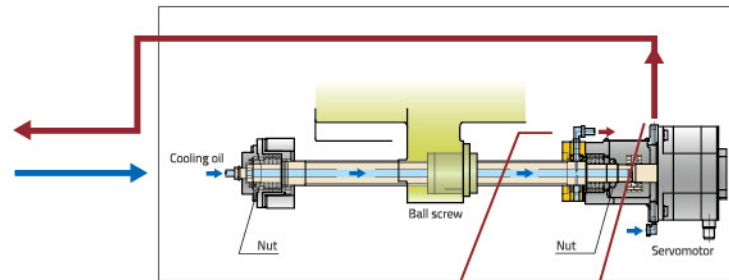

The double-anchoring method is effective for improving the feed mechanism's rigidity and accuracy. Use of the method for the X, Y and Z axes improves the fine-feed and lost-motion characteristics and drastically increases the circular cutting accuracy.

Cutting Data

Face Milling

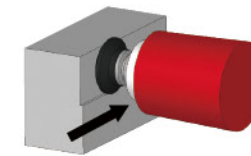

Type of machining	Face milling (Ø125x6T)
Spindle speed	300min ⁻¹
Width of cut	100mm
Depth of cut	5mm
Feed rate	700mm/min
Cutting amount	350cm ² /min
Workpiece material	S45C

Accuracy

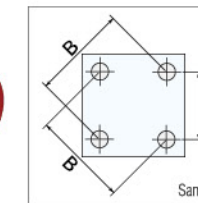
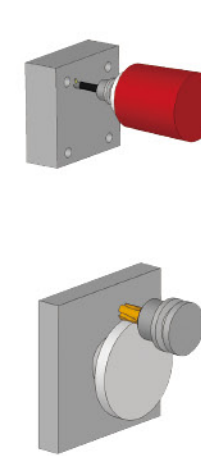

A	200.000 (7.87'')
B	282.843 (11.1355'')

Positioning Machining Accuracy (mm)

Item	Tolerance	Example record
Axial direction	0.015 (0.00059'')	-0.004 (-0.00016'')
	0.015 (0.00059'')	-0.001 (-0.00004'')
Diagonal direction	0.010 (0.00039'')	0.003 (0.00012'')

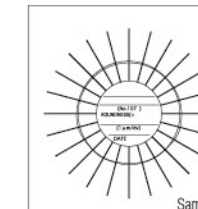

Circular Cutting Accuracy (mm)

Item	Tolerance	Example record
Circularity	0.015 (0.00059'')	0.00413 (0.00016'')

Positioning Accuracy (mm)

Item	When linear scale is not used	When linear scale is used
Positioning accuracy	X:±0.0035(0.00014'') / full length Y:±0.0030(0.00012'') / full length Z:±0.0030(0.00012'') / full length	X:±0.0030(0.00012'') / full length Y:±0.0025(0.00010'') / full length Z:±0.0025(0.00010'') / full length
	X/Y/Z:±0.0020(0.00008'') / full length	X/Y/Z:±0.0015(0.00006'') / full length

(Nidec OKK tolerance)

- Remarks
- The data shown above as an example are based on the short-time machining. The values may vary in the continuous machining.
 - The data shown above as an example were obtained under the Nidec OKK's in-house cutting test conditions. The values may vary with the condition of the cutting tools and fixtures.
 - The above accuracy data are the laboratory data obtained by installing the machine according to the Nidec OKK's foundation drawing and carrying out the inspection based on the Nidec OKK's inspection standard in the environment with constant temperature.

Improved Reliability and Durability

We have considered the measures for chip removal, ease of maintenance, etc. and thoroughly pursued the production efficiency in the long hours of operation.

Design structure in consideration of safety, operability and even the environmental measures

We have improved largely the operability- and chip-processing-related problems that are specific to the large-size machines.

Thorough Chip Processing Measures

The shutter slots have been eliminated from the Y-axis upper and lower covers. Both the table main body and the Z-axis shutter have been steepened to avoid chips accumulation and improve the continuous machining reliability.

The wide troughs on both sides of the table can receive a large amount of chips. The chips and coolant in the troughs are completely transferred and ejected from the machine by means of the coil-type conveyors. The troughs also help to suppress the thermal displacement by sheltering the transfer of heat from chips and coolant to the bed.

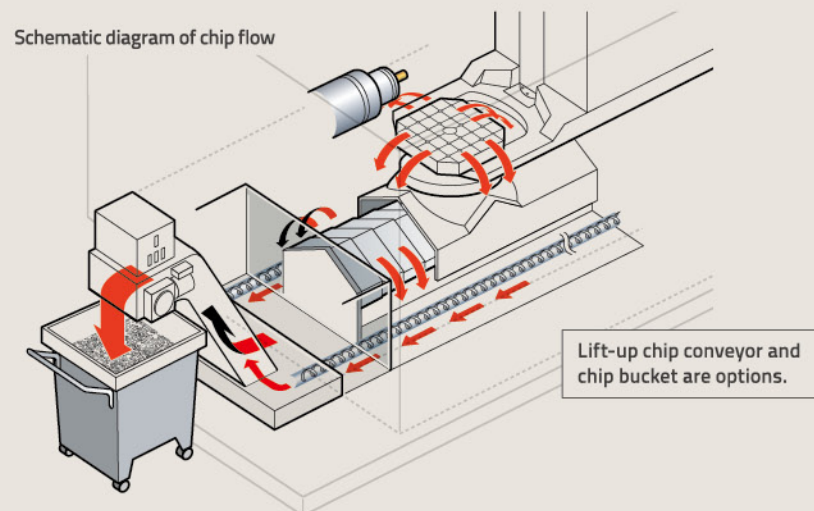

Ceiling Shower [Option]

A large amount of coolant can be jetted and sprayed evenly over the machine inside by using four pumps dedicated to the ceiling shower. The high-capacity ceiling shower washes away chips from fixtures and workpieces and prevents chips from accumulating.

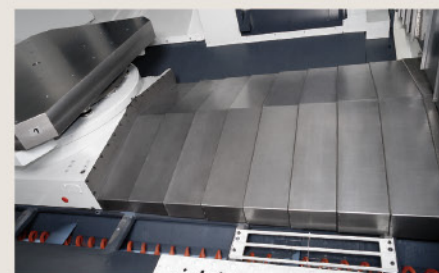

ATC [Automatic Tool Changer]

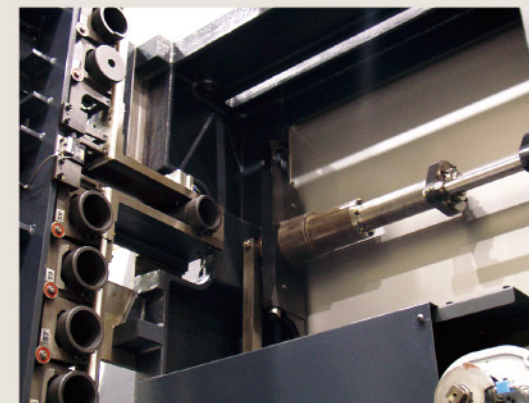

Consistent tool change operation and superior durability are ensured by use of the acknowledged Nidec OKK's original cam-controlled high-speed synchronizing tool changer (Nidec OKK patent). The variable-speed ATC function included in the standard specification allows setting at the time of tool registration for the heavy tools and large-diameter tools so that the ATC turning speed slows down automatically to change those tools smoothly.

Maximum Tool Diameter
ø115mm(4.53")
*ø300 mm (11.81") when the adjoining tool pots are empty.

Tool Exchange Time (tool-to-tool)
3.8s

Maximum Tool Length
600mm(23.62")
*For the multi-magazine that can store 176 or more tools, the maximum tool length for the tools stored in the 3rd or later magazines is restricted to 500 mm.

Tool Exchange Time (cut-to-cut)
11.0s

Maximum Tool Mass
30kg(66.1lbs)

Maximum Tool Moment
29.4N·m
(21.7ft·lbs)

APC [Automatic Pallet Changer]

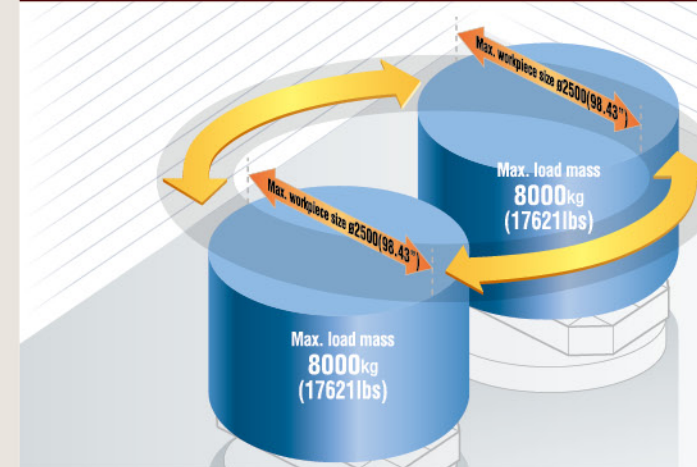

APC [Automatic Pallet Changer]

The APC mechanism of HM1600 uses the direct-turn method consisting only of the pallet lift and turning mechanism so that the pallet exchange time is reduced and space-saving is realized. It can handle the table's maximum load mass of 8000 kg (17621lbs) [option]. Since its design has taken into consideration the expansion for automation (6APC with automatically transferred pallet), it is easily compatible with the line configuration.

Configuration examples 6APC/8APC

Figure is a conceptual diagram. Actual specifications may differ.

HM1600 6APC

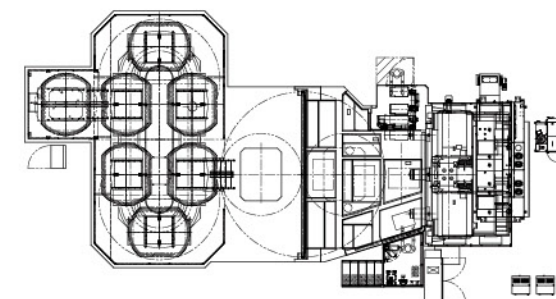

HM1600 8APC

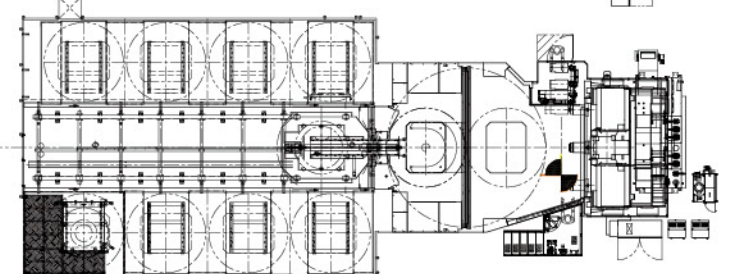

Lift-up Chip Conveyor [Option]

We can provide various types of lift-up chip conveyors.

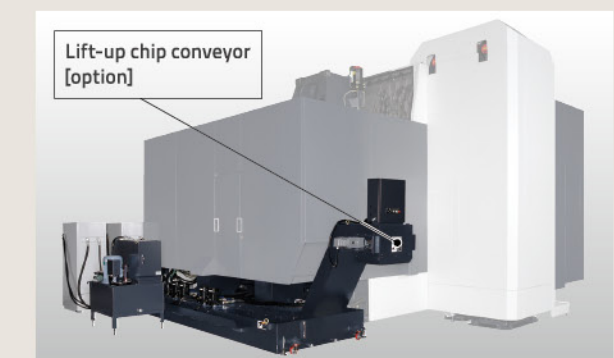

Machine Specification

Main Specification

Item		12000-min ⁻¹ MS	6000-min ⁻¹ gear spindle	8000-min ⁻¹ gear spindle
Travel on X axis (Column's longitudinal direction)	mm	2400(94.49")		
Travel on Y axis (Spindle head's vertical direction)	mm	1650(64.96")		
Travel on Z axis (Pallet's cross direction)	mm	1750(68.90")		
Distance from table top surface to spindle center	mm	100(3.94")~1750(68.90")		
Distance from table center to spindle nose	mm	250(9.84")~2000(78.74")		
Table (pallet) work surface area	mm	1600(62.99")x1250(49.21")		
Max. mass of load on table (pallet)	kg	5000(11013lbs) (Uniformly distributed load)	OP:8000kg(17621lbs) (Uniformly distributed load)	OP:10000kg(22026lbs)** (Uniformly distributed load)
Table (pallet) top surface specification		34 x M20 screw hole at intervals of 250 mm(9.84")		
Minimum indexable angle of table (pallet)	°	0.0001		
Table (pallet) indexing time per 90°	sec	3.5 (Optional 10000-kg(22026lbs) specification: 6.5 sec)		
Spindle rotating speed	min ⁻¹	35~12000	20~6000	20~8000
Number of spindle speeds		2-speed electrical shift (MS)	3-speed gearshift	
Spindle taper hole		7/24 taper No. 50		
Spindle bearing bore diameter	mm	ø100(3.94")	ø120(4.72")	
Rapid traverse rate	mm/min	4200(1653.54") (Optional 10000-kg(22026lbs) specification: 2000 mm/min (78.740ipm))		
Cutting feed rate	mm/min	1~20000 (0.04~787.40ipm) *2		
Type of tool shank		JIS B 6339 BT50		
Type of pull stud		OKK only 90°		
Number of stored tools	tool	60 *3		
Maximum tool diameter	mm	ø115(4.53") (ø300 mm (11.81") with no tools in adjacent pots)		
Maximum tool length (from gauge line)	mm	600(23.62")		
Maximum tool mass	kg	30(66.1lbs)		
Maximum tool moment	N·m	29.4(21.7ft·lbs)		
Tool selection method		Address fixed random method		
Tool exchange time (tool-to-tool)	sec	3.8 (Speed is changeable for heavy tools.)		
Tool exchange time (cut-to-cut)	sec	11 (Optional 10000-kg(22026lbs) specification: 15 sec)		
Pallet exchange method		Direct turn method		
Pallet exchange time (JIS B 6336-9)	sec	54 (Optional 8000-kg(17621lbs) specification: 65 sec)		
Spindle motor (30-min rating/continuous rating)	AC, kW	30/25(40HP/34HP)	45/37(60/50HP)	18.5/15(25HP/20HP)
Motor for ATC	kW	0.75(1HP)		
Feed motors	AC, kW	X:5.0(6.7HP) Y:4.0(5.4HP) Z:5.0(6.7HP) >2 B:4.5(6.0HP)		
Hydraulic pump motor	kW	2.2(3HP)		
Spindle and feed system cooling oil pump motor (compression/discharge)	kW	2.48/0.75x2 (3.3HP/1HPx2)		
Coolant pump motor	kW	1.1(1.5HP)		
Motor for APC	AC, kW	7.0(9.4HP)		
Power supply AC200V±10% 50/60Hz±1Hz AC220V±10% 60Hz±1Hz **	kVA	86	100	70
Compressed air supply	MPa/(min[ANR])	0.4(57.1psi)~0.6(85.7psi), Min500(132.2gpm) ** *5		
Hydraulic unit tank capacity	l	20(5.3gal)		
Spindle and feed system cooling oil tank capacity	l	70(18.5gal)x2		
B axis and magazine lubrication oil tank capacity	l	4.0(1.1gal)		
Coolant tank capacity	l	800(211.4gal)		
Machine height	mm	4370(172.05")		
Required floor space	mm	7485(294.69")x10770(424.02") (Opt. lift up chip conveyor)		
Machine mass	kg	50000(110132lbs) (Optional 10000-kg(22026lbs) specification: 40000 kg(88105lbs))		
Operating environment temperature	°C	5~40		
Operating environment humidity	%	10~90 (No condensation)		

Note 1: The APC cannot be used for the 10000-kg(22026lbs) specification.
 Note 2: Feed rate under the HQ or Hyper HQ control.
 Note 3: The number of stored tools refers to the total number of tools including the one installed on the spindle i.e. subtract one from the above for the actual number of tools stored in the tool magazine.
 Note 4: The values for the standard specification machines are described above. They are subject to change because of the added options.
 Note 5: Purity of the supplied air should be equivalent to or higher than Class 3.5.4 specified in ISO 8573-1/JIS B8392-1.

Standard Accessories

Item	Qty	Remarks
Separate coolant tank	1 set	
Slideway protection covers for X, Y and Z axes	1 set	
Top cover / APC safety guard	1 set	
Earth leakage breaker	1 set	
Automatic power off	1 set	
Lighting system (Two lamps inside the machine)	1 set	
Signal lamp (2-lamp type)	1 set	
Edge locator	1 set	
Direct-turn APC unit	1 set	
Chip conveyors (Two for table both sides)	1 set	Coil type inside the machine for chip discharge from rear side
Hydraulic unit	1 set	
Guide and ball screw automatic greasing		Lubricating the linear guides and ball screws
Spindle and feed system cooling oil temperature controller	1 set	
Oil-air unit	1 set	
B axis and magazine automatic lubrication	1 set	
Steps inside the machine	1 set	
Work platform for the operator	1 set	Shared with the equipment box
Foundation parts (for the bond anchoring method)	1 set	Including the bond for foundation
Instruction manual	1 copies	
Electrical instruction manual (including electrical diagrams)	1 copy	

Special Accessories

Item	Specification
Increased spindle motor output	45/30/26kW(60/40/35HP) (12000-min ⁻¹ MS specification) 22/18.5kW(30/25HP) (8000-min ⁻¹ gear-spindle specification)
Two-surface locking tool	BT type
Tool removing device	
Changing the type of pull stud	MASI 45° MASII 60°
Number of stored tools	116 / 176 / 236 tools
Multi-pallet APC	
Pallet top face specification	T-slot specification / Special specification
Addition of pallets	
Maximum mass of load on the table	8000 kg(17621lbs) (uniformly distributed load) 10000 kg(22026lbs) (uniformly distributed load without APC)
APC safety door automatic operation	
Oil skimmer	
Addition of lighting system	
Signal lamp	3-lamp type with buzzer / 3-lamp type without buzzer
Linear scale	For X, Y and Z axes / For X and Y axes
Coolant-through-spindle	2-MPa(285psi) coolant / 7-MPa(1000psi) coolant / Air mist
Coolant cooler	
Spare Thickener bag filter	6 pieces (1 set)
Air blow nozzle	1 nozzle
Oil mist blower	
Minimal quantity lubrication system	External nozzle specification / Spindle-through specification
Swirl stopper block	For oil hole / For angle attachment
Piping for the oil-hole block	Normal pressure (1.2 kW)(1.6HP) / High pressure (2 MPa)(285psi)
Ceiling shower	
Workpiece cleaning equipment	Shower gun type
Mist collector	
Lift-up chip conveyor	Hinged-pan type / Scraper type / For aluminum chips Scraper type with floor magnet / For aluminum/Fc chips with magnet separator
Conveyor chip bucket	Fixed type / Swing type
Machine coating color	Color specified by customer
Standard tool set	Including a tool box
Air dryer	
Fire extinguishing appliance	
Sub table	T-slot / Hole / Special specification
Mass block	T-slot / Hole / Special specification
Angle plate	T-slot / Hole / Special specification
2-face angle plate	T-slot / Hole / Special specification
Fixture	
Tooling	
Rotary table, tail stock	
Vice	
Touch sensor system T1	Workpiece measurement (T1-A) / Tool length measurement, Tool break detection (T1-C)
Tool break detection inside the magazine	
Tool presence/absence detection	

Controller

FANUC Controller F31i-B Plus

Standard Specification
No. of controlled axes: 4 axes (X, Y, Z, B)
No. of simultaneously controlled axes: 3 axes(BRT specification is 4 axis)
Least input increment: 0.001mm / 0.0001"(X,Y,Z) 0.0001deg(B(BRT))
Max. programmable dimension:±999999.999mm/±39370.0787"
Absolute / Incremental programming: G90 / G91
Decimal point input/Pocket calculator type decimal point input
Inch/ Metric conversion: G20 / G21
Program code: ISO / EIA automatic discrimination
Program format: FANUC standard format
FS15 tape format
Nano interpolation (internal)
Positioning: G00
Linear interpolation: G01
Circular interpolation: G02 / G03 (CW/CCW)(Including radius designation)
Helical interpolation
Unidirectional positioning: G60
Cutting feed rate: 6.3-digit F-code, direct designation
Rapid traverse override: 0 / 1 / 10 / 25 / 50 / 100%
Cutting feed rate override: 0 to 200% (every 10%)
Feed rate override cancel: M49 / M48
Rigid tapping: G84, G74 (Mode designation: M29)
Manual handle feed: Least input increment x1, x10, x100 / graduation
Dwell: G04
One-digit F code feed
inverse time feed
Part program storage capacity: total 10240m [4MB] (total 1000 programs)
Part program editing
Background editing: Possible to program or edit the machining program while NC machining is executed.
Extended part program editing
15-inch color LCD/QWERTY key MDI
Clock function
MDI (manual data input) operation
Run hour and parts count display
Memory card / USB interface
Spindle function: Direct designation of spindle speed with 5-digit S-code
Spindle speed override: 50 to 150% (every 5%)
Tool function: Direct designation of called tool number with 4-digit T-code
ATC tool registration
Auxiliary function: Designation with 3-digit M-code
Multiple M-codes in 1 block: Maximum 3 codes in 1 block (Maximum 20 settings)
Tool length offset: G43, G44 / G49
Tool diameter and cutting edge R compensation: G41, G42 / G40
Tool offset sets: total 400 sets
Tool offset memory C
Tool position offset
Automatic reference position return: G28 / G29
2nd reference position return: G30
Machine coordinate system: G53
Coordinate system setting: G92
Automatic coordinate system setting
Workpiece coordinate system: G54 to G59 G54.1 P1~P48
Local coordinate system: G52
Polar coordinate command: G15, G16
Manual reference position return
Reference position return check: G27
Optional block skip: /
Single block
Dry run
Machine lock

Standard Specification
Z-axis feed cancel
Auxiliary function lock
Graphic function
Program number search
Sequence number search
Program restart
Cycle start
Feed hold
Manual absolute (ON/OFF with PMC parameter)
Auto restart
Program stop: M00
Optional stop: M01
Sequence number collision and stop
Sub program control
Canned cycle: G73, G74, G76, G80 to G89
Mirror image function parameter
Custom macro
Programmable mirror image
Programmable data input: G10
Automatic corner override
Manual Guide i (Basic)
Exact stop check / mode
Scaling: G50, G51
Additional custom macro common variables: 1000
Coordinate system rotation: G68, G69
Optional chamfering / corner R
Playback
Memory pitch error compensation (interpolation type)
Backlash compensation for each rapid traverse and cutting feed
Smooth backlash
Skip function
Tool life management: total 256 sets
Tool length manual measurement
Data protection key
NC alarm display / alarm history display
Machine alarm display
Stored stroke check 1
Stored stroke check 2
Load monitor
Self-diagnosis
Absolute position detection

Optional Specification
Additional one axes control: name of axis (A, C, U, V, W) **
Additional two axes control: name of axis (A, C, U, V, W) **
No. of simultaneously controlled axes: 5 axes **
Least input increment: 0.0001mm / 0.00001"
Spiral / Conical interpolation
Cylindrical interpolation
Hypothetical axis interpolation
Involute interpolation
NURBS interpolation
Smooth interpolation (Hyper HQ control B mode is required)
Handle feed 3 axes: Standard pulse handle is removed
Part program storage capacity: total 20480m [8MB] (1000 in total)
Machining time stamp
Data server: ATA card (1GB)
Data server: ATA card (4GB)

(WindowsCE-Installed Open CNC)

Optional Specification
RS232C interface: RS232C-1CH
Spindle contour control (Cs contour control)
Tool position offset
Tool offset sets: total 499 sets
Tool offset sets: total 999 sets
Addition of workpiece coordinate system (total 300 sets): G54.1 P1 to P300
Optional block skip: Total 9
Manual handle interruption
Tool retract and return
Figure copy
Interruption type custom macro
Instruction of inclined plane indexing
Chopping
Manual Guide i (Milling cycle)
Addition of tool life management sets: total 1024 sets
High-speed skip

Original Nidec OKK Software
Integrated machining support software (incl. help guidance, etc.) STD
Tool support STD
Program Editor STD
EasyPRO STD
Work Manager [Opt]
HQ control STD
Hyper HQ control mode A [Opt]
Hyper HQ control mode B [Opt]
Hyper HQ varue kit ** [Opt]
Special canned cycle (including circular cutting) [Opt]
Cycle Mate F [Opt]
Soft Scale II m STD
Touch sensor TO software [Opt]
Soft CCM (Tool failure detection system) [Opt]
Soft AC (Adaptive control unit) [Opt]
Automatic restart at tool damage [Opt]

Note 1: F31i-B5 Plus (WindowsCE-Installed Open CNC)
 Note 2: Includes Data server: ATA card (1GB) and Hyper HQ control mode B
 STD: Standard [Opt]: Option

Machine Dimensions

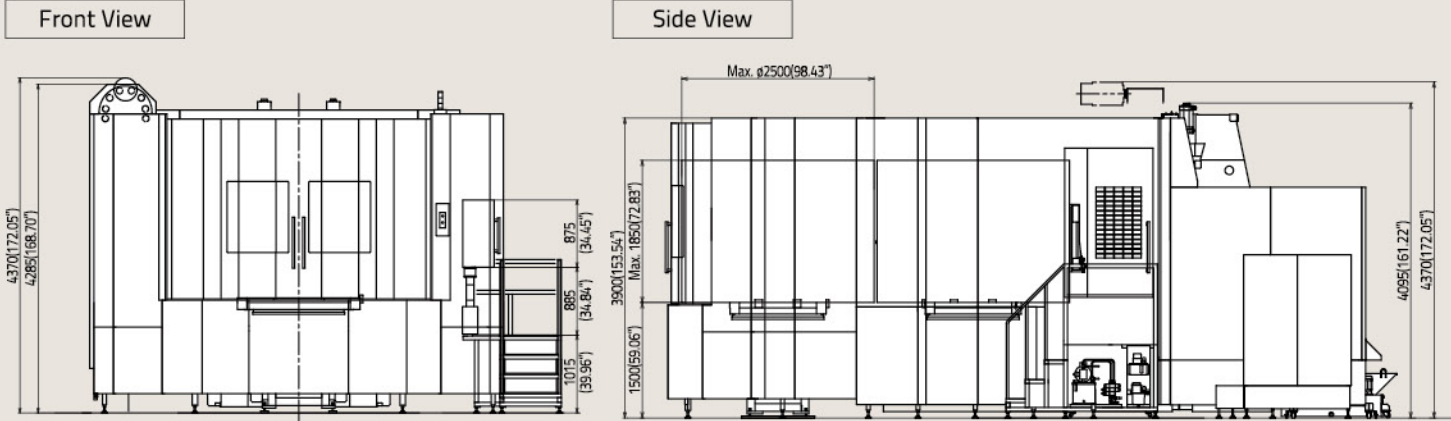

Floor Space Diagram

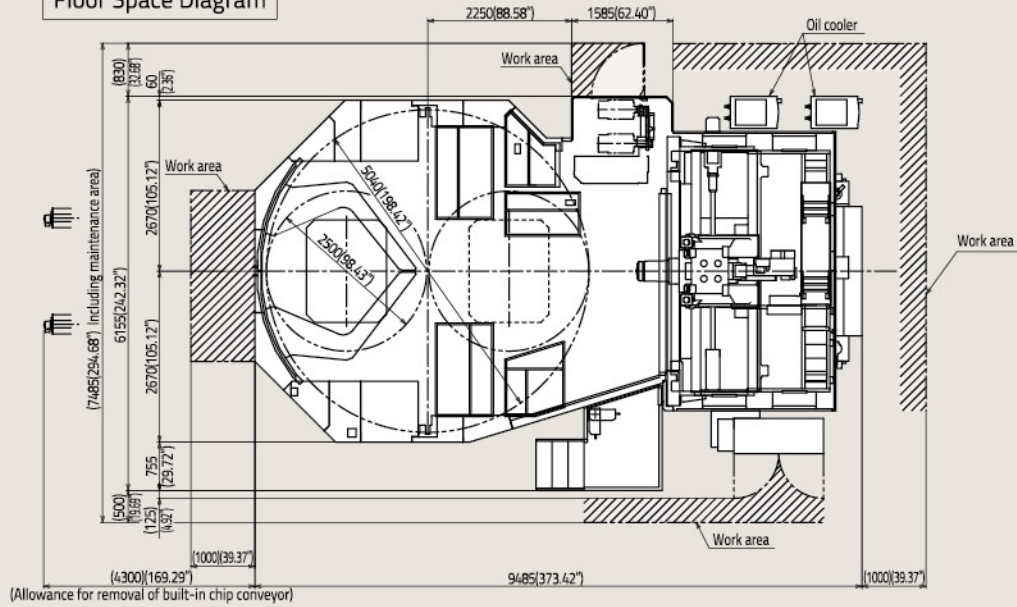

Floor Space Diagram [Option]

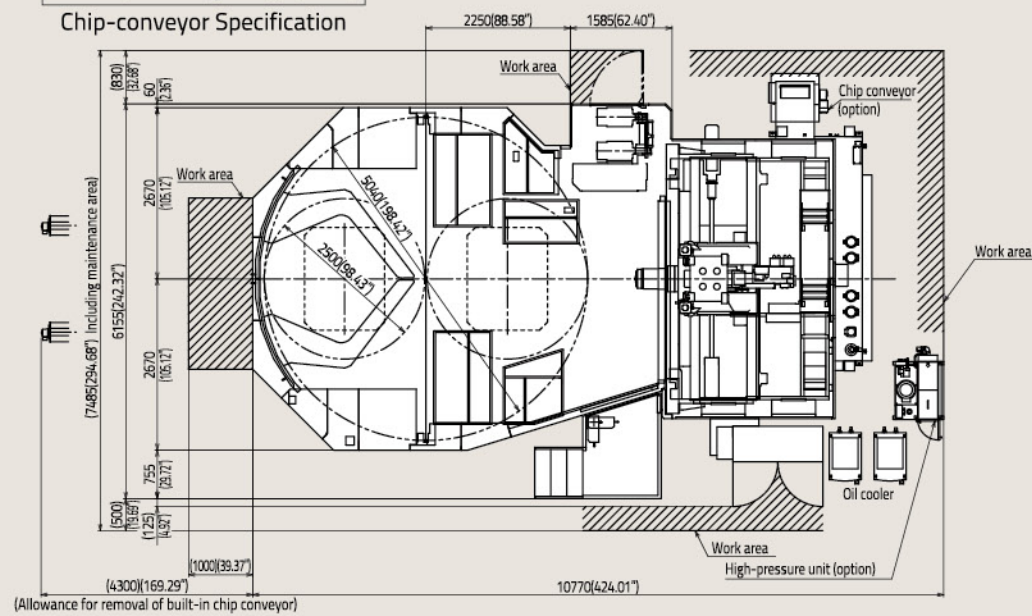

Restrictions on Workpiece

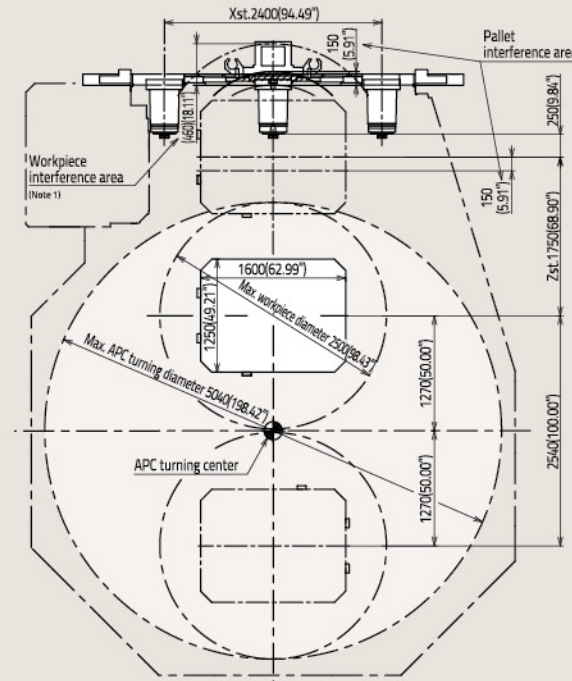

Note 1: When the APC operation is used, do not load a workpiece that exceeds the range of the maximum APC turning diameter shown above.

Stroke Diagram

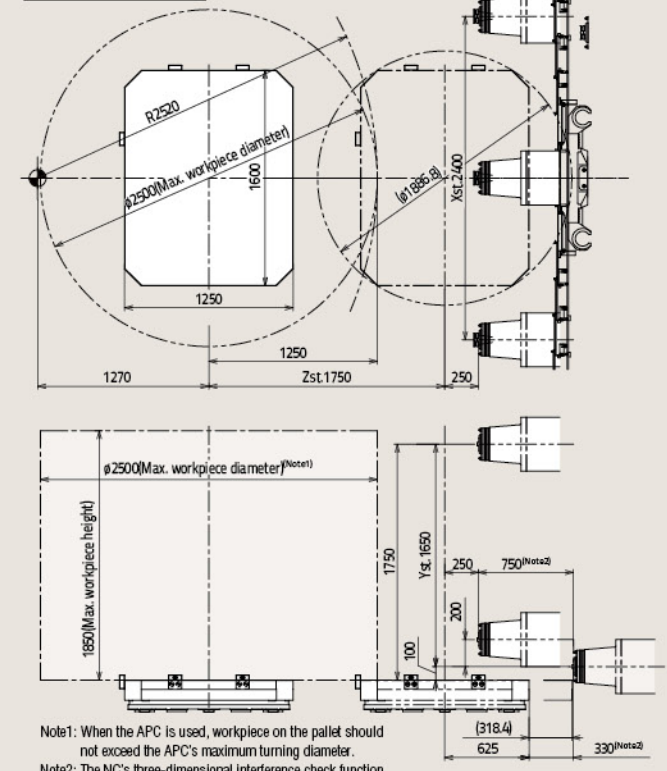

Note1: When the APC is used, workpiece on the pallet should not exceed the APC's maximum turning diameter.
Note2: The NC's three-dimensional interference check function prevents the pallet from colliding with the head or the X- or Y-axis shutter.

Spindle Shape and Dimensions

12000-min⁻¹ MS Specification

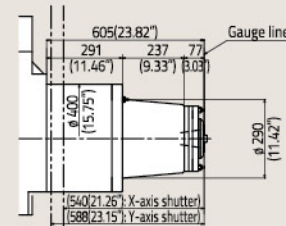

8000-min⁻¹ Gear Spindle Specification

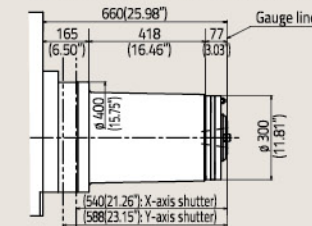

6000-min⁻¹ Gear Spindle Specification

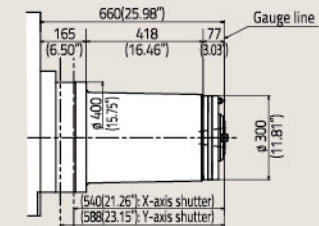

Restrictions on Tool

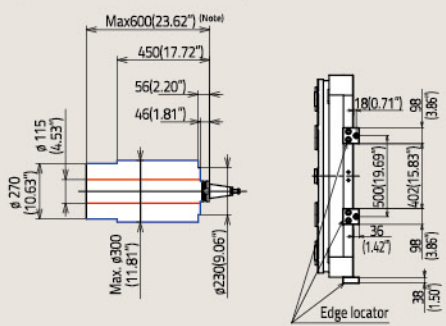

Note: For the multi-magazine that can store 176 or more tools, the maximum tool length for the tools stored in the 3rd or later magazines is restricted to 500 mm (19.69").

Screw Hole Specification [Standard]

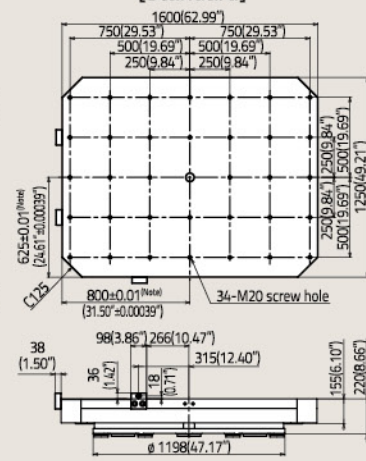

Note: This dimension is the dimension between the center of rotation and the edge locator. Please also note that the pallet center hole does not always correspond to the center of rotation.

Pallet Dimensions

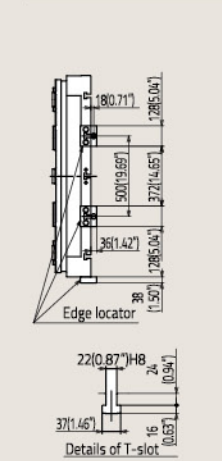

T-slot Specification [Option]

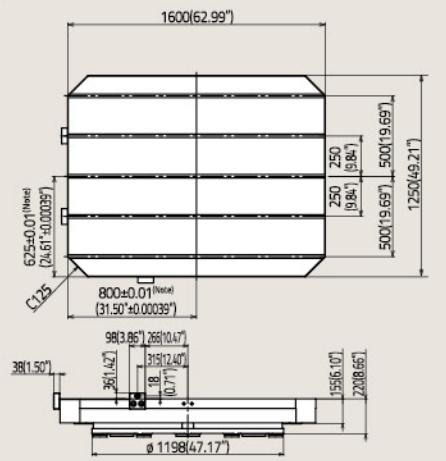

Note: This dimension is the dimension between the center of rotation and the edge locator.



HM1600/10t

10000-kg(22026lbs) Maximum Load Mass Specification

The 10000-kg(22026lbs) maximum load mass specification machine can be provided for machining dies and molds and large and heavy parts.
(APC unit is not available. Rapid traverse rate: 20000 mm/min(787.40ipm) for X, Y and Z axes and 2.5 min⁻¹ for B axis)

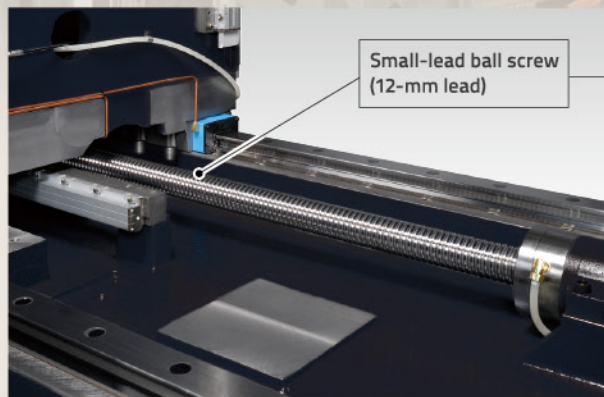

Small-lead ball screw (12-mm lead)

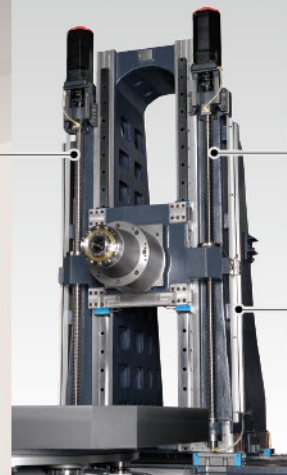

Small-lead ball screw (12-mm lead)

Linear scale [option]

Main Specification

Item	Unit	10000-kg(22026lbs) Specification
Travel on X axis (Column's longitudinal direction)	mm	2400(94.49")
Travel on Y axis (Spindle head's vertical direction)	mm	1650(64.96")
Travel on Z axis (Pallet's cross direction)	mm	1750(68.90")
Distance from table top surface to spindle center	mm	100(3.94")—1750(68.90")
Distance from table center to spindle nose	mm	250(9.84")—2000(78.74")
Table (pallet) work surface area	mm	1600(62.99")×1250(49.21")
Max. mass of load on table (pallet)	kg	10000(22026lbs)
Max. workpiece size (diameter × height)	mm	∅2500(98.43")×1850(72.83")

Item	Unit	10000-kg(22026lbs) Specification
Rapid traverse rate	mm/min	X/Y/Z: 20000(787.40ipm)
Number of stored tools	tools	60
Maximum tool diameter	mm	∅115(4.53") (∅300 mm(11.81") when the adjoining tool pots are empty.)
Maximum tool length (from gauge line)	mm	600(23.62")
Maximum tool mass	kg	30(66.1lbs)
Required floor space	mm	6625(260.83")×7230(284.65")
Machine height	mm	4370(172.05")
Machine mass	kg	40000(88105lbs)

10000-kg(22026lbs) Specification Machine Main Dimensions

Workpiece Loading Diagram

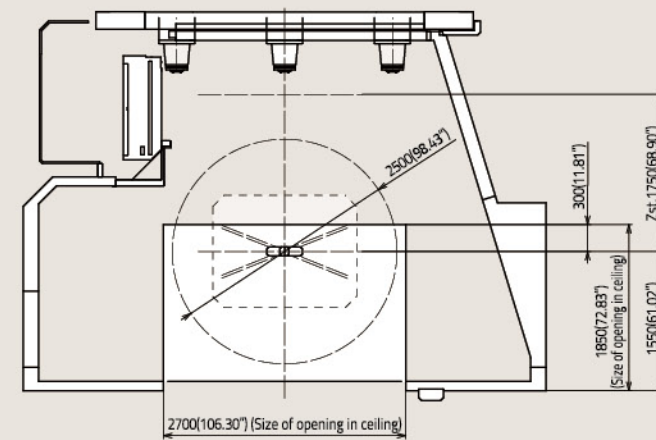

*Pallets have the same dimensions as the ones for the standard machine.

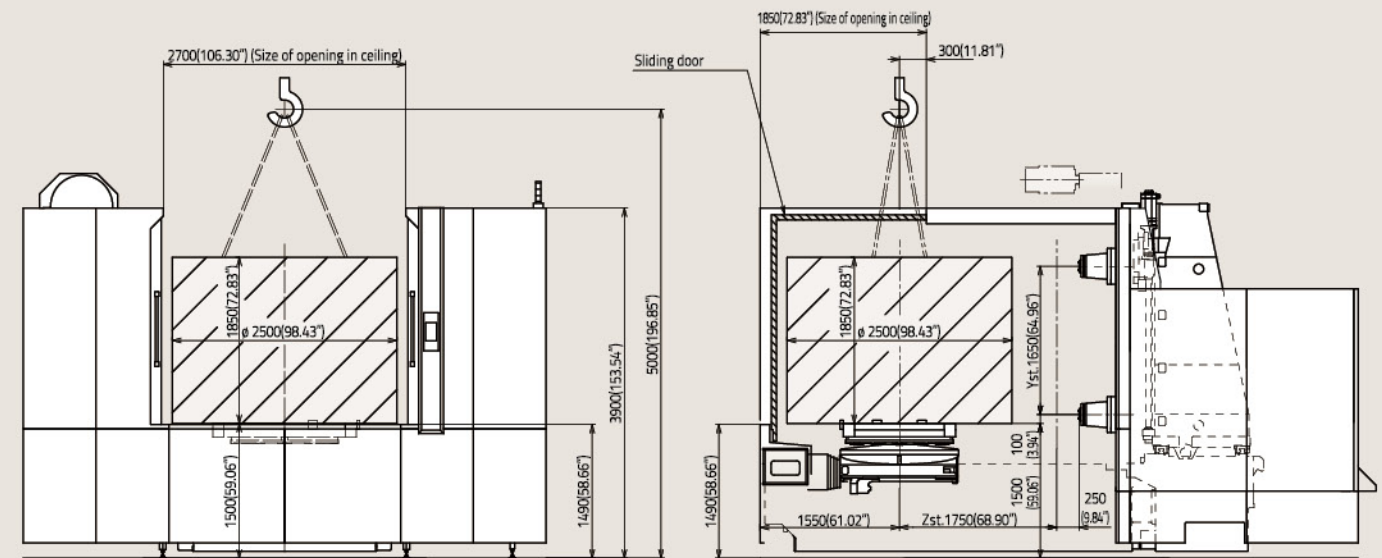

Floor Space Diagram [Option]
Chip-conveyor Specification

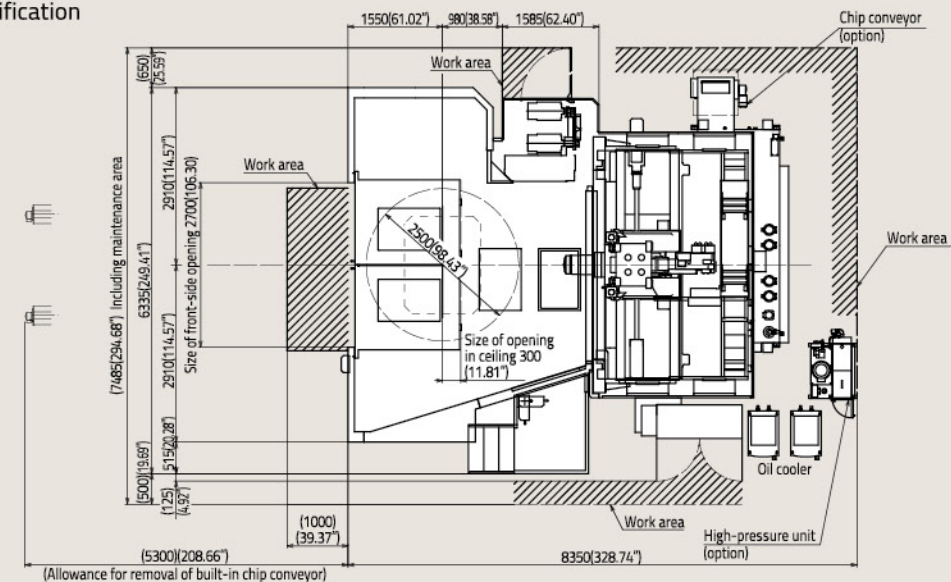



NIDEC OKK CORPORATION

**8-10, KITA-ITAMI, ITAMI
HYOGO 664-0831 JAPAN**
International Sales Department
TEL: (81)72-771-1143
www.nidec.com/en/nidec-okk/
E-mail: nokk.ovsd@nidec.com

NIDEC OKK A DIVERSIFIED MANUFACTURER OF MACHINE TOOLS

Specializes In:

Machining centers
Graphite cutting machining centers
Grinding centers
CNC Milling machines
Conventional milling machines
Total die and mold making systems
Flexible manufacturing cells and systems

NOTE :

NIDEC OKK reserves the right to change the information contained in this brochure without notice.
NIDEC OKK is not responsible to make changes to previously sold machines or accessories.
The machines in the photographs of this brochure may include optional accessories.

The export of this product is subject to an authorization from the government of the exporting country.
Check with the government agency for authorization.

NIDEC OKK USA CORPORATION

101 South Gary Avenue, Suite B, Roselle, IL 60172, U.S.A
TEL: (1)630-924-9000

NIDEC OKK Europe GmbH

HANSEMANNSTR 33 41468 NEUSS, GERMANY
TEL: (49)2131-29868-0
FAX: (49)2131-29868-41

NIDEC OKK Machinery (THAILAND) Co., Ltd.

KUMTHORN HOLDING BUILDING 2nd FLOOR 897-897/1 Rama 3
Road, Bangpongpan, YANNAWA, BANGKOK 10120 THAILAND
TEL: (66)2-683-2160-2
FAX: (66)2-683-2163

NIDEC OKK (SHANGHAI) CO., LTD.

12F, TOWER B, 100 ZUNYI ROAD, CHANG NING DISTRICT,
SHANGHAI, CHINA
TEL: (86)21-62700930
FAX: (86)21-62700931