

PM type Stepping Motors MSGN series

■ MSGN series



■ Applications

Information equipment

■ Characteristics

REACH RoHS compliant

■ Standard specifications

Size (mm)	Φ10 × L11.4	
Weight (g)	11.0	
Resistance (Ω)	25.1	
Rated voltage (V)	7.5	
Driving waveform	Rectangle	
Excitation	2 phase	
Step angle (°)	18.0	
Step accuracy (%)	25	
Holding torque (mN·m)	1.8	
Detent torque (mN·m)	0.1	
Max self start frequency (pps)	1390	
Power supply type	FPC	○
	Lead wire	
	Pin connector	
Operating temperature (°C)	-10~70	

■ Dimensions / Torque characteristic

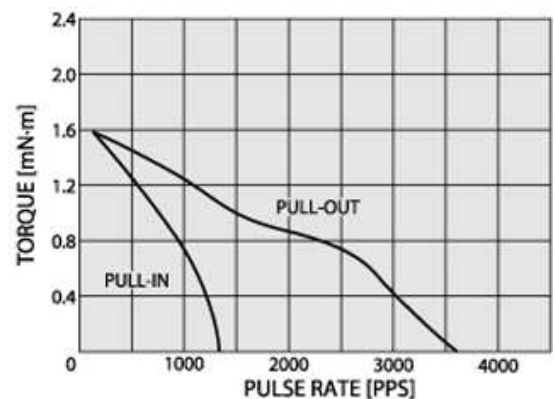
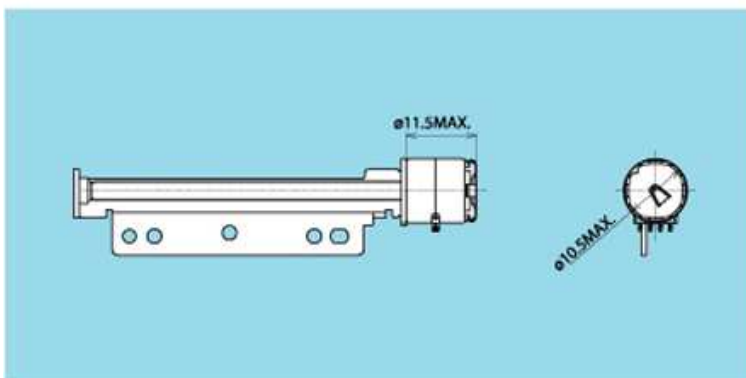

Characteristic data is based on standard specifications

NIDEC SANKYO CORPORATION

For additional information, please contact our sales.

Tokyo Office

Nidec Tokyo Bldg., 1-20-13 Osaki, Shinagawa-ku, Tokyo 141-0032, Japan Tel:(81)3-5740-3000