

PM type Stepping Motors MSDU series

MSDU series



Standard specifications

Size (mm)	Φ3.4 × L4.8	
Weight (g)	0.3	
Resistance (Ω)	25	
Rated voltage (V)	3.0	
Driving waveform	Rectangle	
Excitation	2 phase	
Step angle (°)	18.0	
Step accuracy (%)	20	
Holding torque (mN·m)	0.06	
Detent torque (mN·m)	0.005	
Max self start frequency (pps)	3000	
Power supply type	FPC	○
	Lead wire	
	Pin connector	
Operating temperature (°C)	-10~70	

Applications

Camera instrument

Characteristics

REACH and RoHS compliant

Environmentally friendly

Dimensions / Torque characteristic

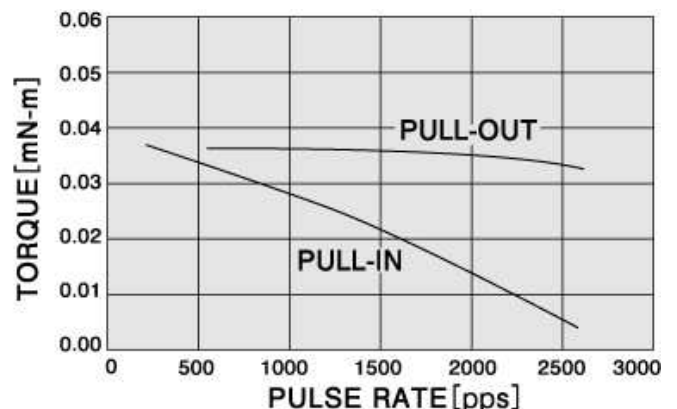
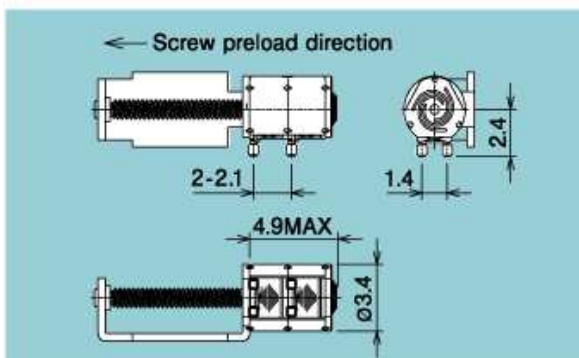

Characteristic data is based on standard specifications

NIDEC SANKYO CORPORATION

For additional information, please contact our sales.

Tokyo Office

Nidec Tokyo Bldg., 1-20-13 Osaki, Shinagawa-ku, Tokyo 141-0032, Japan Tel:(81)3-5740-3000